

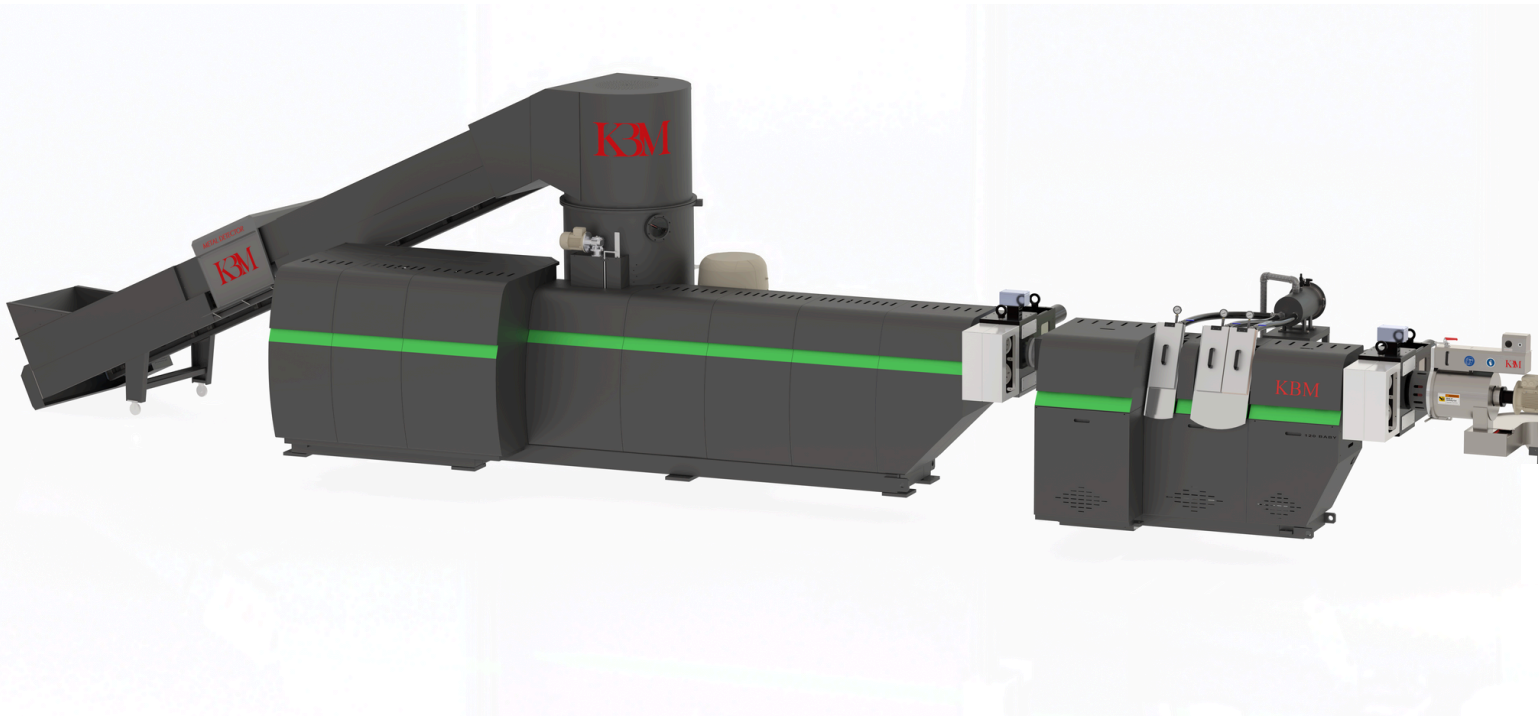

RE 
CYCLE
FOR BETTER TOMORROW
SINCE 45 YEARS

Recycling

KBM



Washing Line

PE-PP Film & HD-PP Chips



Before washing



After washing



- With our washing line we aim to provide a full start to end solution.
- Input of PCR and output of washed and dry waste ready to be fed into the extrusion line

Squeezer



FEATURES :

- Used for reducing the moisture content in film waste after exposure to washing process
- Post squeezing, moisture content will be between 8% - 12%

Before Squeezing



After Squeezing



Single Stage

Industrial Films & Rigid waste

Applicable Plastic Materials:

PP ,BOPP, CPP, HDPE, LDPE, PET, EPE, EPS



- Great for inhouse clean waste
- Smaller sized machine
- Low Energy consumption

Shredder

100 kg to 1500 kg per hour

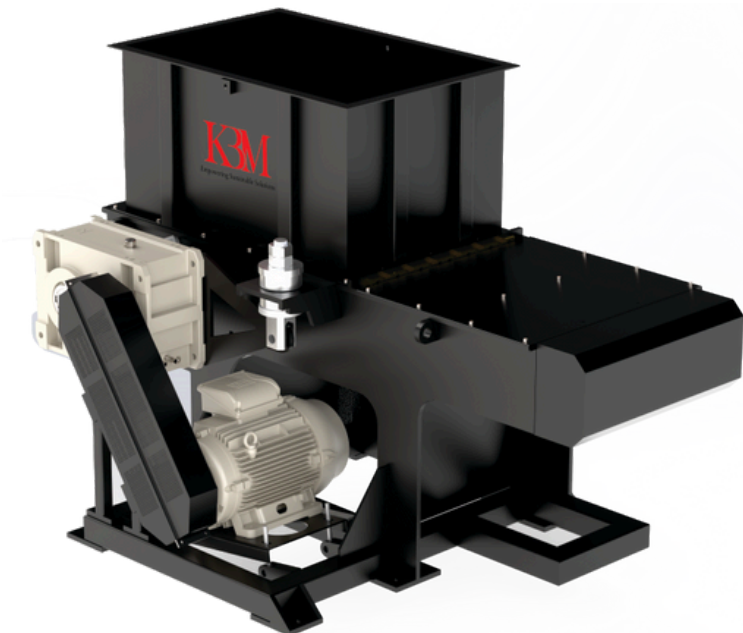

FEATURES :

- Multi-material Capability:
Able to shred various types of plastic (PP,PET,PVC,HDPE,PP RAFIA etc.) efficiently
- Four Edge knife Technology
- Durable Blades and Cutting Mechanisms
- Safety Features
- High Throughput and Energy Efficient
- Automatic Feeding Facility

Bigger the Better

1000+ kg/hr & Power Saving

KBM



Our 1 ton/ hour PET Extrusion line that uses washed PET Bottle Flakes to be converted into pellets. These can be used to make BOPET film

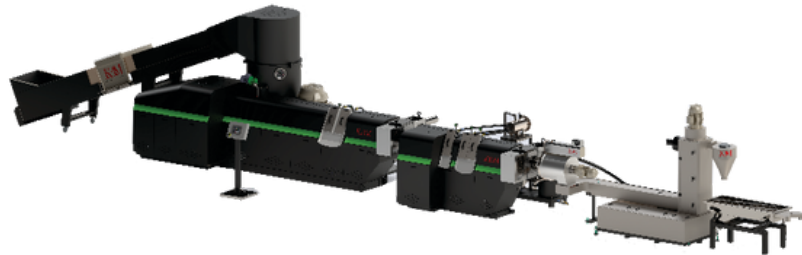

Our 1ton/hour HDPE Chips Cutter compacter Extrusion line with a special triple vent in the baby to guarantee top quality granules

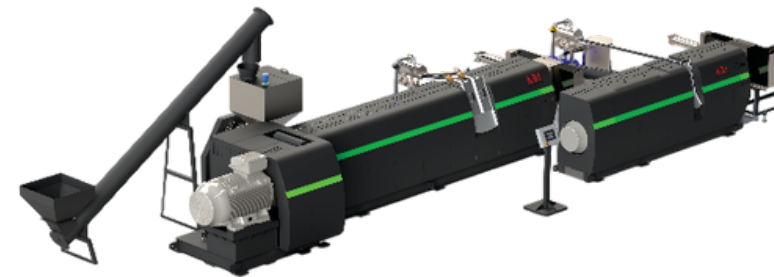

Our 1ton/hour PP Chips Extrusion line with a side feeder reaching its highest quality granules post strand pelletizing

Our Outreach



KBM PLASTIC MACHINERY LLP

Mfg. of : Extrusion Machines

Factory : B-9/10, J.K. Industrial Estate, H.NO. 1376, Behind Hotel Novelty,
Village - Kherpada, Virar East - 401305, Mumbai, India.

CONTACT US

+91 9607838454

info@kbmextrusions.com | info@kbmail.com

www.kbmextrusions.com

FOLLOW US 