

Probably

THE WORLD'S SAFEST WHEEL NUT



THE DISC-LOCK SAFETY WHEEL NUT

with NEW environmentally friendly, anti-corrosion coating

DISC-LOCKTM
EUROPE

LEADING INNOVATORS IN FASTENER TECHNOLOGY



Vehicle Safety Invention Award

www.disc-lock.co.uk

Disc-Lock Safety Wheel Nut



The vibration and shock-proof wheel nut for trucks, trailers and buses which eliminates the risk of wheel loss.*

*As confirmed by MIRA Tests (see back page)

The Disc-Lock Safety Wheel Nut:

- maintains wheels on axles
- is approved by vehicle and axle manufacturers
- is fitted by major fleet operators worldwide
- is as simple to install as a standard two-piece wheel nut

What is the Disc-Lock Safety Wheel Nut?

The **Disc-Lock** Safety Wheel Nut is a vibration proof wheel nut, specifically designed to prevent wheel loss from commercial vehicles such as trucks, trailers and buses. **Disc-Lock** Safety Wheel Nuts are considered to be far superior in terms of safety than standard two-piece wheel nuts. The shock and vibration, which cause standard wheel nuts to come loose, cause **Disc-Lock** Safety Wheel Nuts to **lock**, thus maintaining the clamp load and keeping the wheel on the axle.

How does the Disc-Lock Safety Wheel Nut work?



Unlike a standard two-piece wheel nut, the **Disc-Lock** Safety Wheel Nut is split into three sections, comprising a nut (1), a hexagon-flanged washer (2) and a flat faced cup washer (3). These sections are joined together to form a one-piece assembly with an O/ring.

The top two sections (1 & 2) have interlocking cams. When subjected to road shock or vibration, the most common causes of wheel nut loosening, the interlocking cams of the **Disc-Lock** Safety Wheel Nut attempt to rise against each other.



The angle of the cam (DL) is greater than the pitch angle of the thread on the stud (T).

$DL > T$

As the angle of the cam is greater than the pitch angle of the thread on the stud, a wedging action takes place and the **Disc-Lock** Safety Wheel Nut **locks** and will not come loose, thus maintaining the clamp load and keeping the wheel on the axle.

New features for 2006

Disc-Lock is always working hard to find ways in which to improve its products. Main new features of this latest version of the **Disc-Lock** Safety Wheel Nut are:

- 1 Indestructible** - The nut has been strengthened considerably to overcome the problems caused by air-gun abuse. Though, it should be noted, that while the **Disc-Lock** Safety Wheel Nut can now withstand such abuse, the same cannot be said of the stud. This could experience untold damage, in particular stretching of the stud, if the wheel nut is severely over torqued.
- 2 Better socket engagement** - The height of the middle hexagon-flanged washer (see section 2 in diagram on left) has been increased to give better socket engagement.
- 3 New, environmentally-friendly coating - GEOMET®.** The **Disc-Lock** Safety Wheel Nut is now coated with a new, environmentally-friendly, anti-corrosion protection, GEOMET®, which is chrome free, ensuring it is compliant with European Union Directive 2002/95/EC (Restriction of Hazardous Substances). This new coating has passed a 720 hours salt spray test.

The patented **Disc-Lock** system is approved by vehicle and axle manufacturers throughout Europe and the **Disc-Lock** Safety Wheel Nut is fitted by many truck and bus fleets worldwide who recognise the Nut as an essential safety device.

What the experts say:

*"The **Disc-Lock** nut should be encouraged and publicised because practical experience shows that it does make a major contribution to road safety and it is the most significant improvement to wheel security for years".*

Eur Ing Don H Wright, Bsc (Eng), CEng, FI MeChE.



All the vehicles pictured here are fitted with **Disc-Lock** Safety Wheel Nuts.

Disc-Lock Safety Wheel Nut Dimensional Chart

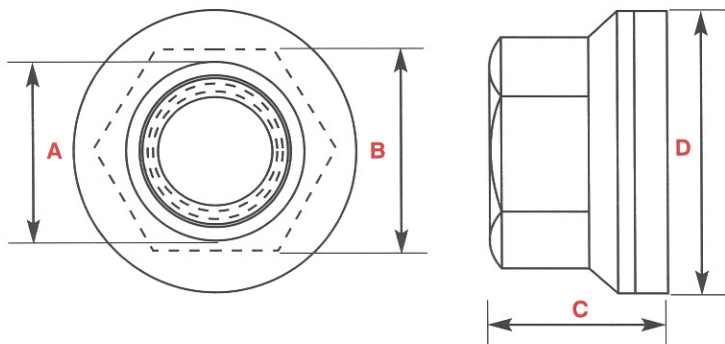

SIZE & THREAD	WIDTH ACROSS THE FLATS	HEIGHT	FLANGE DIAMETER
A	B	C	D
M18 x 1.5	34.0mm	29.0mm	47.5mm
M20 x 1.5	34.0mm	29.0mm	47.5mm
M20 x 2.5	34.0mm	29.0mm	47.5mm
M22 x 1.5	38.0mm	34.0mm	52.0mm
7/8" - 11BSF (Scania)	38.0mm	34.0mm	52.0mm
7/8" - 14UNF	38.0mm	34.0mm	52.0mm

How to install & remove the Disc-Lock Safety Wheel Nut



The **Disc-Lock** Safety Wheel Nut is easy to install and remove. Indeed, it is installed in exactly the same way as a standard two-piece wheel nut.

To install or remove, simply place the socket over the hexagon nut and hexagon flanged washer and tighten or loosen.

Refer to axle manufacturer's instructions for torque settings.

A detailed installation instruction leaflet and workshop poster is available on request to *Disc-Lock Europe*, tel +44 (0)1795 844332 or email info@disc-lock.com.

Disc-Lock Safety Wheel Nuts keep wheels secure if maintained and fitted correctly.

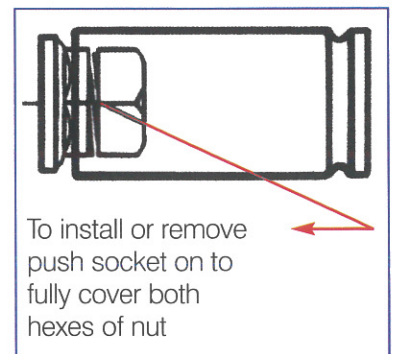

Disc-Lock Safety Wheel Nut On Test

MIRA Test

In December 2004 the **Disc-Lock Safety Wheel Nut** underwent a severe performance test at the Motor Industrial Research Association (MIRA) Proving Ground in Nuneaton, Warwickshire, UK.

A fully-laden semi-trailer/tractor-unit combination (weight 35 ton) was fitted with **Disc-Lock Safety Wheel Nuts** on the nearside and standard two-piece wheel nuts on the offside.

Over a two-day period the vehicle was driven around a figure-of-eight track to apply lateral bending movements to the wheels. In addition, repeated forward and rearward emergency braking was undertaken to induce torsional slipping forces to the wheels. At the completion of each cycle of thirty minutes a torque check was undertaken.



Actual truck and trailer used for the MIRA Test.

These checks revealed no loss of torque on any of the Disc-Lock Safety Wheel Nuts at any stage.

The same could not be said of the standard two-piece wheel nuts, a staggering 50% of which had come loose by the end of the test.

To obtain a detailed copy of this MIRA Test report call *Disc-Lock Europe* on +44 (0)1795 844332, send an e-mail request to info@disc-lock.com or go to the following link <http://www.disc-lock.com/article.asp?VID=104> to download a copy.

Junker Vibration Test



Disc-Lock Safety Wheel Nuts are tested on a Junker Vibration Test machine which is named after its German designer Gerhard Junker. Junker's theories are based in part on the so-called "long-form torque equation" relating the torque applied to a fastener to the frictional and elastic reactions to that torque. The Junker Test machine works as follows: an eccentric cam generates a controllable amount of transverse displacement on the joint under test. A load cell measures the actual transverse forces exerted on the joint. One can determine the relationship between residual preload in the fastener under test and external vibratory forces created by the test machine as a function of time.

When tested against a standard two-piece wheel nut on a Junker Test machine the **Disc-Lock Safety Wheel Nut** remains secure under the most severe vibration conditions while the standard two-piece wheel nut comes completely loose.

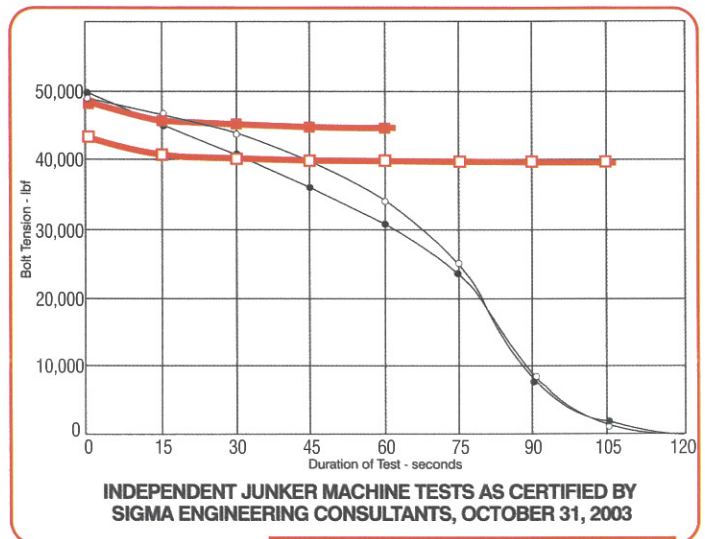

- 7/8 x 11 BSF, 450 lbf.ft (610 Nm)
- ◻ 7/8 x 11 BSF, 450 lbf.ft (610 Nm)
- ◻ **Disc-Lock Nut, 515 lbf.ft (698 Nm)**
- **Disc-Lock Nut, 450 lbf.ft (610 Nm)**

DISC-LOCK
EUROPE
LEADING INNOVATORS IN FASTENER TECHNOLOGY

TCB House, Clywedog Road South, Wrexham Industrial Estate, Wrexham, LL13 9XS, UK

Tel: +44 (0)1978 668123

Email: info@disc-lock.co.uk www.disc-lock.co.uk

www.disc-lock.co.uk